

TD1850 Multi-function Calibrator

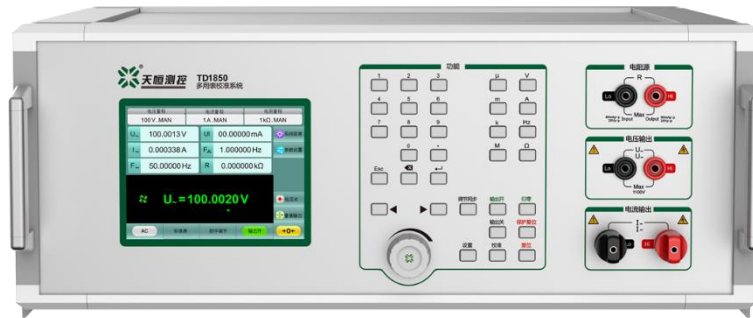

1. Summary

TD1850 is a multi-function calibrator, integrates AC\DC voltage source, AC\DC current source, DC resistance source, etc. The accuracy class is 0.05. It's applied to calibrating 3.5 digits multimeter, voltmeter, ammeter, ohmmeter.

2. Features

- DC voltage output: 20 mV ~ 1100 V
- DC current output: 2 μ A ~ 22 A (33 A is optional)
- AC voltage output: 20 mV ~ 1100 V
- AC current output: 200 μ A ~ 22 A (33 A is optional)
- Sinusoidal wave frequency: 45 Hz ~ 1100 Hz
- Simulated DC resistance: 10 Ω ~ 220 M Ω , continuously adjustable.
- 2 MHz pulse frequency output
- Multiple value output modes
- Remote adjustment (optional)
- Clamp meter calibration (optional)
- Transducer calibration(optional)

3. Application

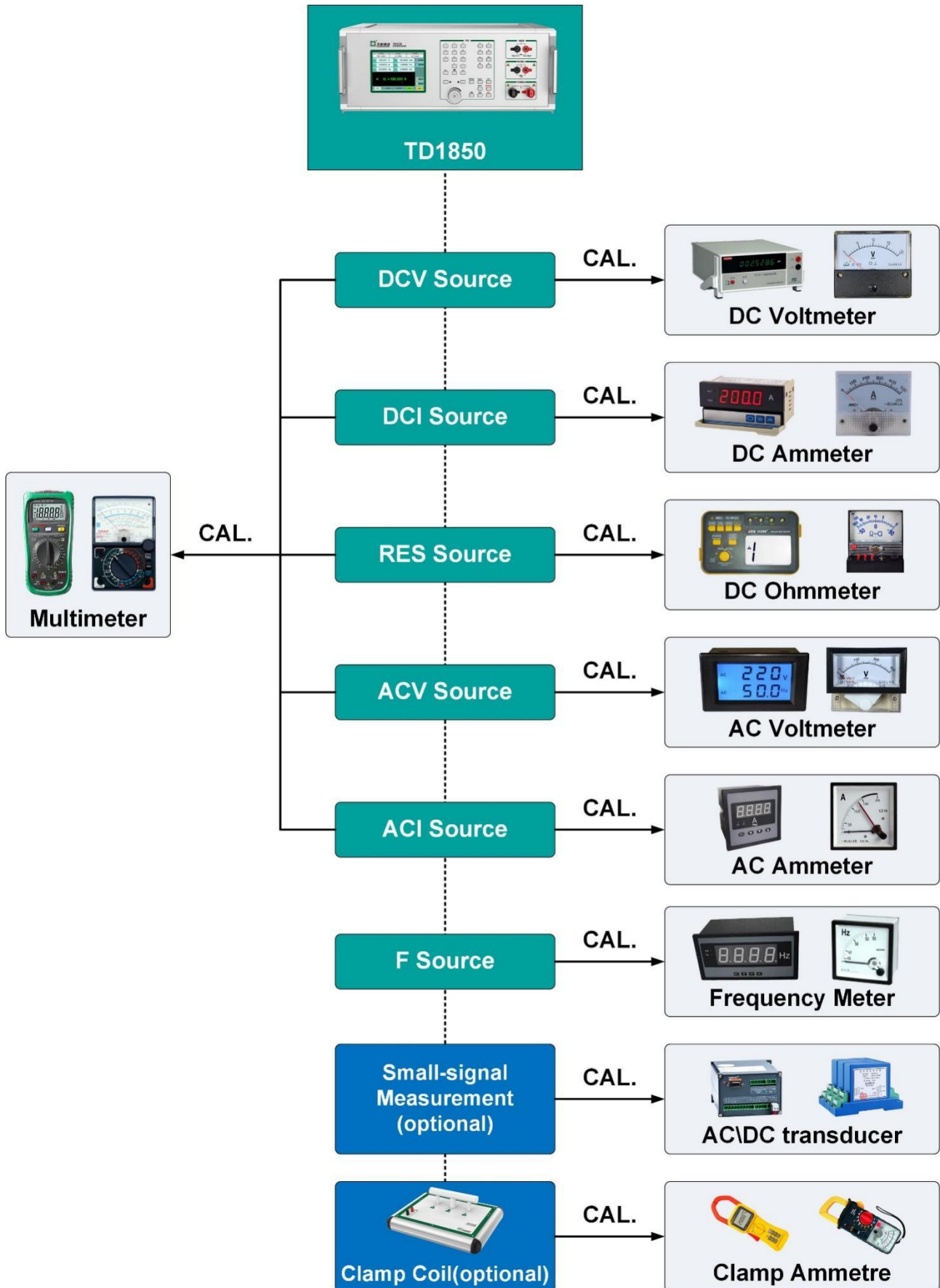

☆ Calibrate AC/DC electrical measuring instruments

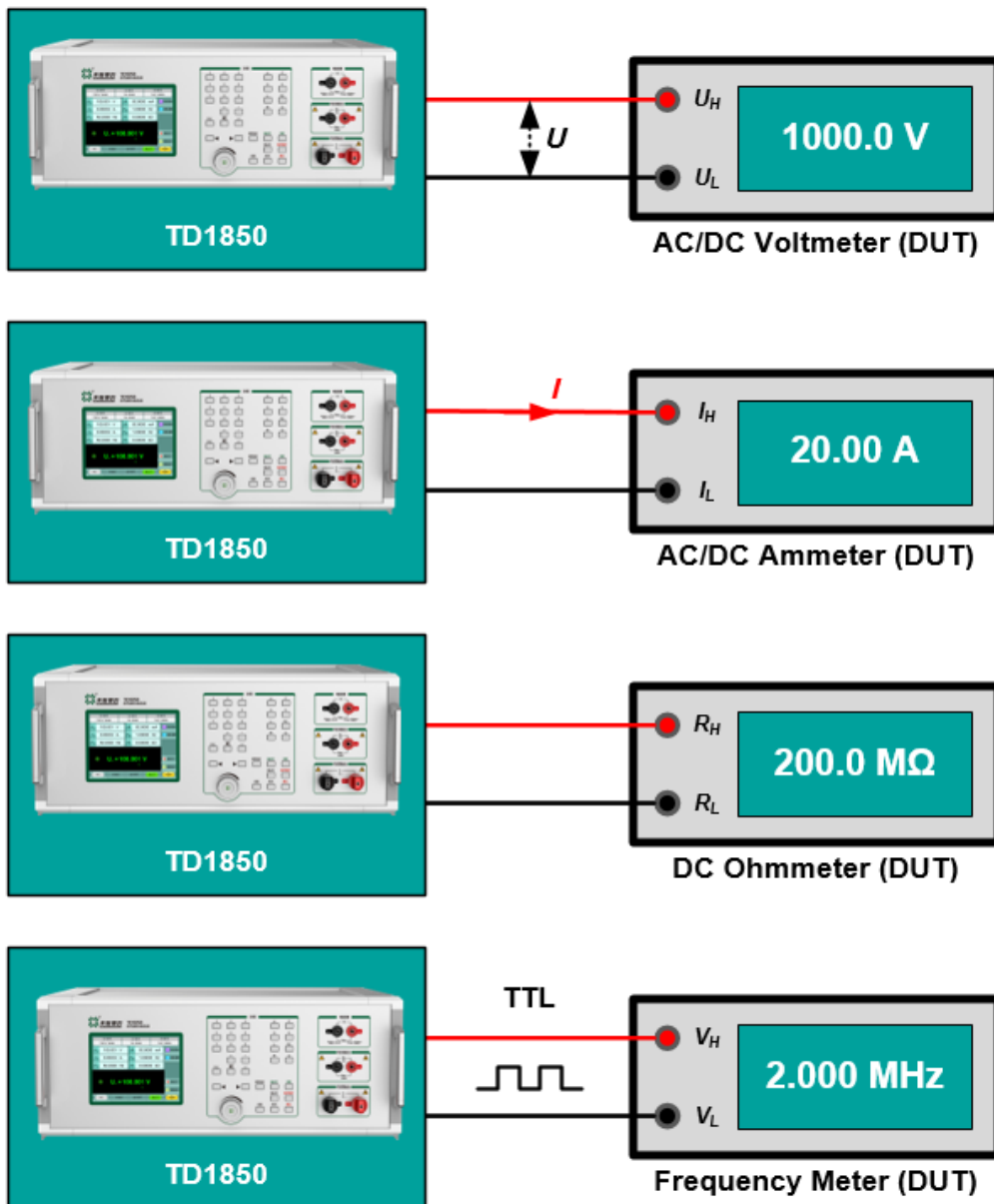

- **DCV output:** 20 mV ~ 1100 V
- **DCI output:** 2 μ A ~ 22 A or 33 A
- **ACV output:** 20 mV ~ 1100 V, 45 Hz ~ 1100 Hz
- **ACI output:** 200 μ A ~ 22 A or 33 A, 45 Hz ~ 1100 Hz
- **RES output:** 10 Ω ~ 220 M Ω
- **Frequency output:** 1 Hz ~ 2 MHz
- Suitable for calibrating three-and-a-half-digit multimeters, AC and DC voltmeters, AC and DC ammeters, resistance meters of class 0.2 and below, and frequency meters of class 0.01 and below.

☆ Calibrate clamp ammeter (optional)

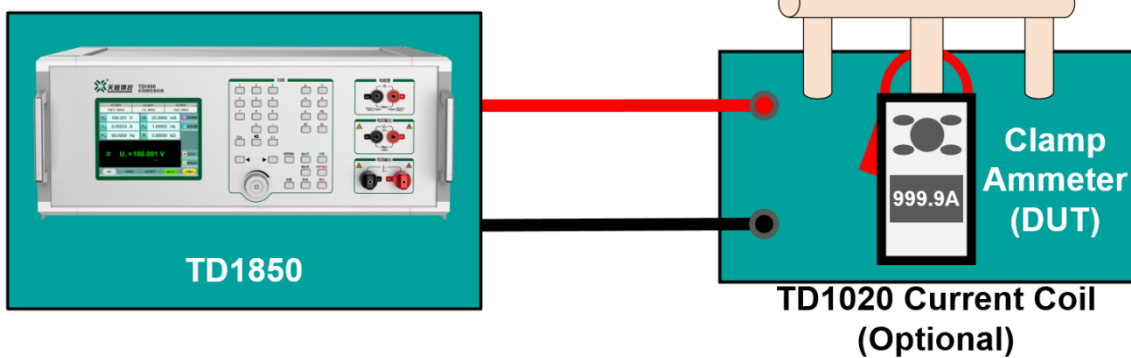

- Users can choose TD1020 current coil (50 turns), pass 20 A AC and DC standard current, and achieve equivalent current output of up to 1000 At, which is suitable for calibrating clamp ammeters or current clamps with lower accuracy levels of level 1 and below.
- If you need to calibrate a clamp ammeter with higher accuracy, you can choose Tunkia TD1050 clamp ammeter calibration device product.

☆ Calibrate AC/DC Transducer (optional)

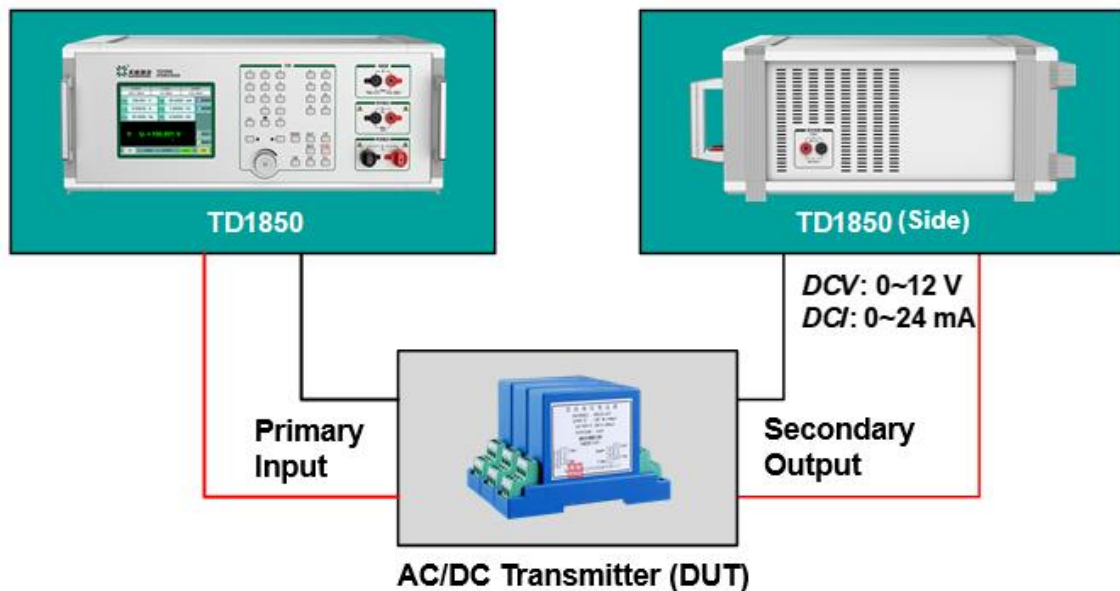

- DC small-signal measurement. (V_{max} : 12 V, I_{max} : 24 mA)
- Calibrate the proportional error of AC/DC voltage/current transducer.

4. Panel Features

☆ Front\Side Panel

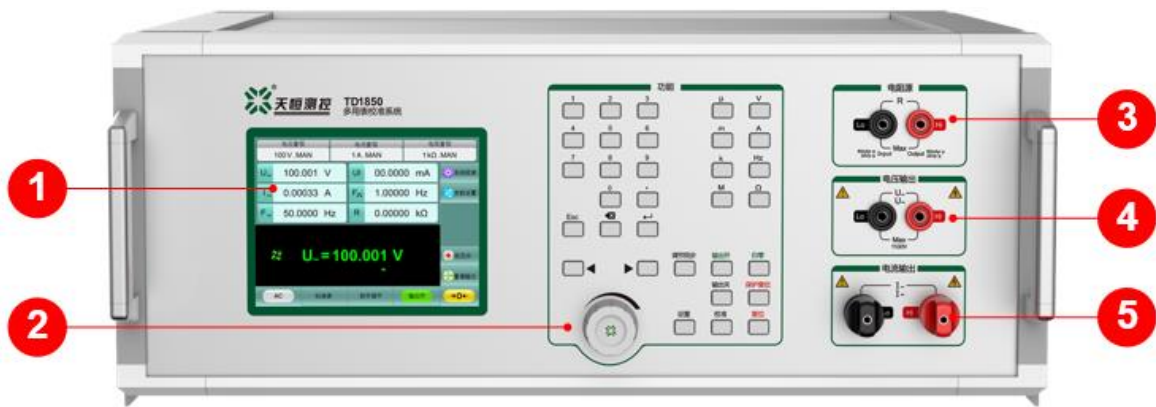

Figure(a) Front Panel

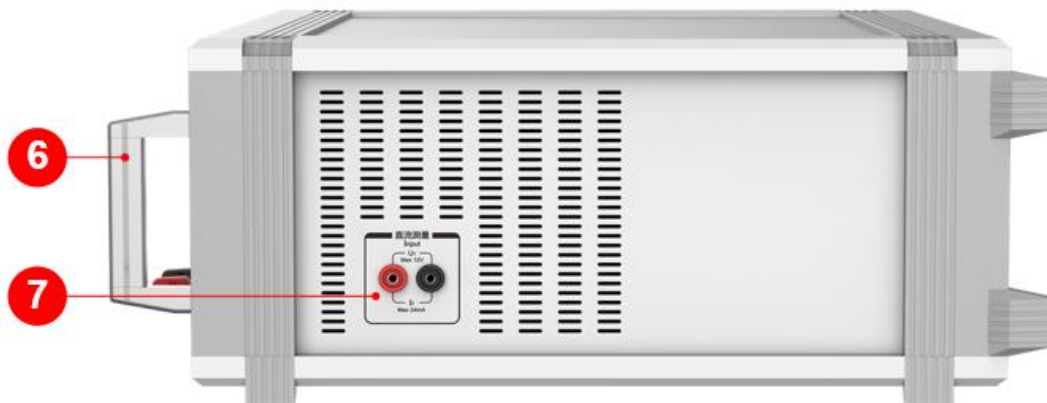

Figure(b) Side Panel

Item	Description
1	LCD touch screen: intuitive display of multiple power levels and touch operation greatly improves the usability of the instrument.
2	Key operation panel: multiple value input and adjustment modes greatly improve the convenience of instrument operation.
3	DC analog resistance output terminal: two-wire connection mode.
4	AC and DC voltage output terminal: adopts protective terminal to prevent high voltage danger caused by misoperation.
5	AC and DC current output terminal: can be connected to $\Phi 4$ safety banana or U-shaped plug, and supports a maximum current of 22 A or 33 A.

6	Handle: The front panel is equipped with a pair of handles to facilitate users to move or carry the instrument.
7	DC transmitter secondary signal input terminal: supports the input of a maximum DC 24 mA or 12 V signal.



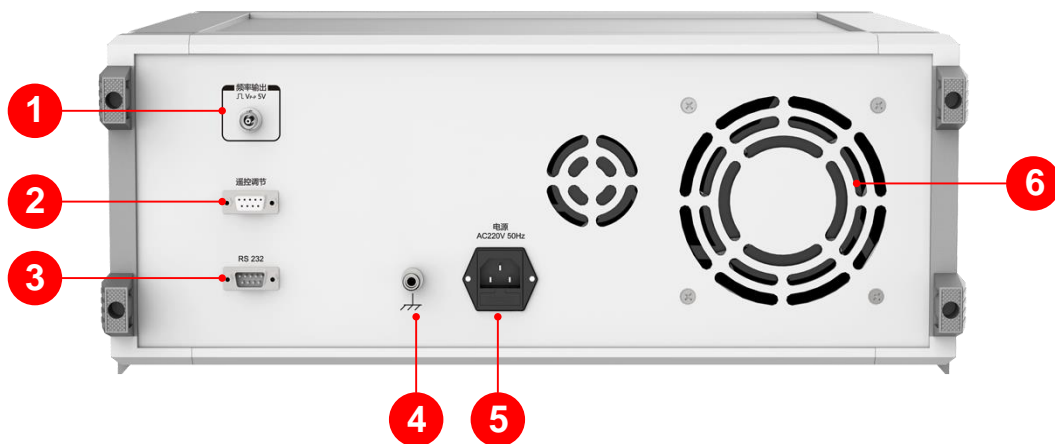



☆ Rear panel



Item	Description
1	Pulse frequency output terminal: BNC female.
2	Remote control box interface: Connect the remote control box (optional) via a control cable.
3	RS232 communication interface: Can be connected to a computer to facilitate user programming and control of the output of the multi-function standard source.
4	Case ground interface: The instrument should be grounded before operation to ensure power safety.
5	Power interface: AC 220V power input interface with fuse.
6	Instrument heat dissipation port: Heat is dissipated through the built-in radiator and fan to ensure the stability of the internal temperature of the instrument and improve measurement accuracy.

5. Characteristics

☆ Wide output range

	1 μ	1m	1	1k	1M	1G
DCV	20 mV  1100 V					
DCI	2 μ A  22 A / 33 A					
RES	1 Ω  220 M Ω					
ACV	20 mV  1100 V					
ACI	200 μ A  22 A / 33 A					
F _r	45 Hz  1100 Hz					
F _{rL}	1 Hz  2 MHz					

- **Solution value:** The multifunctional standard source output range of TD1850 covers the working range of electrical measuring instruments such as 3.5 digital multimeters, and can be calibrated directly using the standard source method.

☆ High load capacity

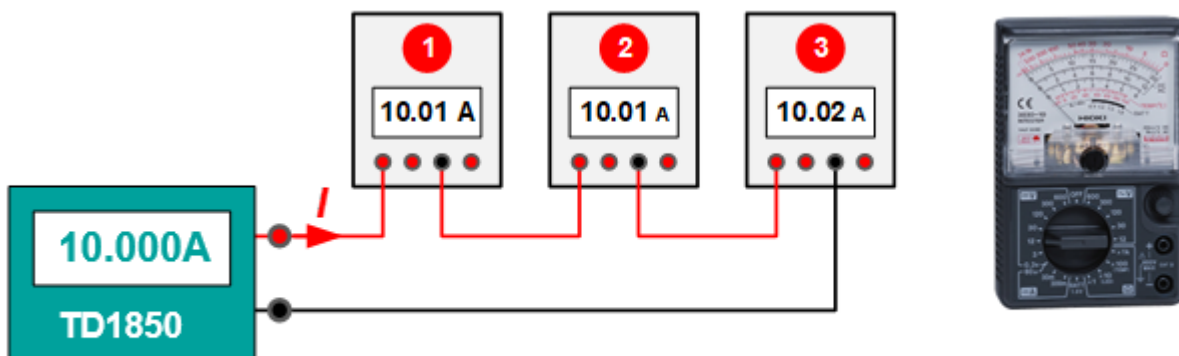
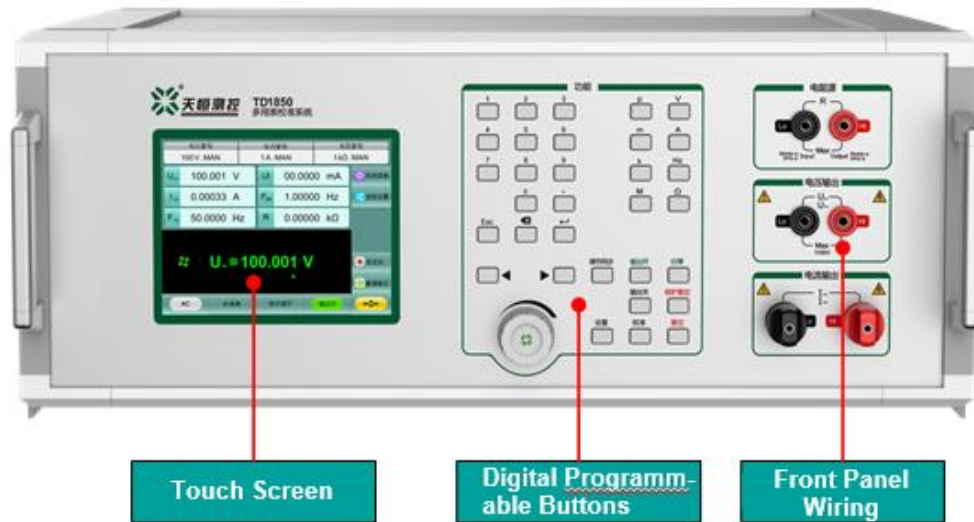

Figure (a) Supports simultaneous calibration of multiple digital meters

Figure (b) Pointer-type analog meter

- **Solution advantages:** TD1850 has a high load capacity and can be used to calibrate multiple digital meters at the same time, as shown in Figure (a). In addition, when connected to analog pointer meters and other meters that require high drive capabilities, the instrument can still maintain high-precision and high-stability constant voltage or constant current output.

☆ Easy to operate



- **Large-size touch screen:** full color, high screen brightness, clear picture quality, support touch operation, comprehensive functions, simple and fast.
- **Digital programmable buttons:** can realize multiple input methods such as fixed-point output, rotary encoder, and step adjustment, and the operation is convenient and fast.
- **Front panel wiring:** convenient for users to replace current and voltage test wires when checking the meter.
- **Solution value:** This combined operation method effectively improves the convenience of operation to adapt to a variety of application scenarios.

☆ Multiple output\adjustment methods

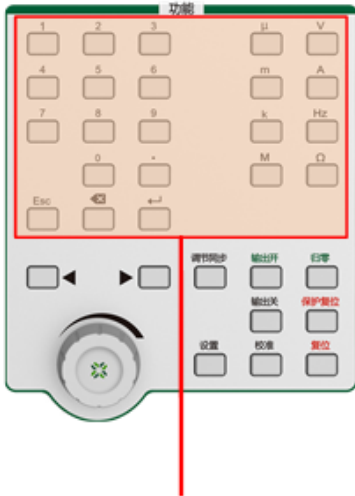

Figure(a) Keypad

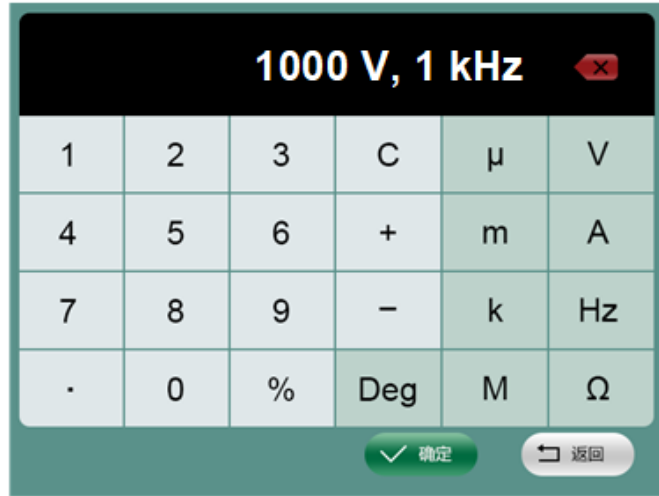

Figure(b) Touch Screen Output

- The instrument has a " **direct output** " mode. You can directly set the required output value by pressing the digital buttons on the console or clicking the touch screen. The instrument will automatically switch to the optimal range output, making it very convenient to calibrate digital instruments.
- Especially when setting the AC voltage/current output, you can directly enter the amplitude and frequency at the same time (as shown in Figure b above), which is very convenient to use.

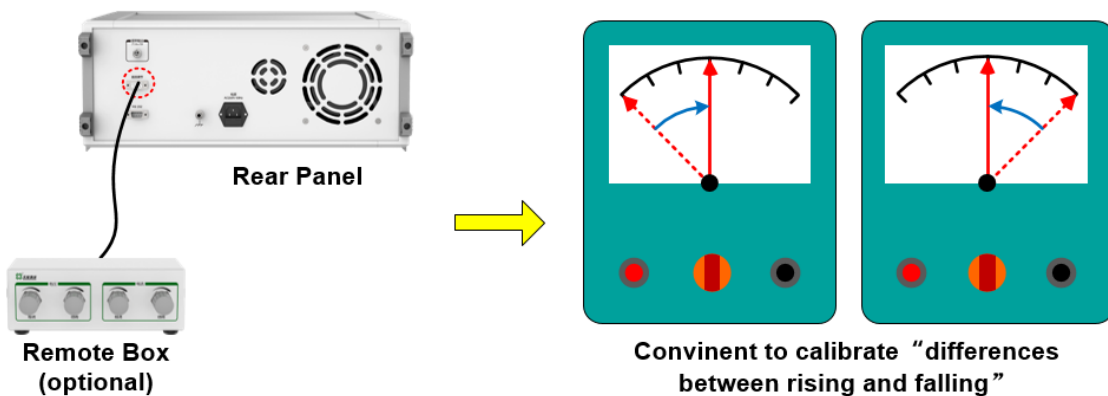

- The calibration of analog pointer type usually needs to be carried out scale by scale, especially the "rising and falling variation" (i.e. the change caused by the rise and fall of the tested point), and the output of the source needs to be adjusted to align the indicator of the tested table with the graduation line of the tested point.

- It is relatively inconvenient to use the digital fixed-point output method to adjust the output of the standard source to achieve the alignment of the scale.
- For this reason, we provide users with a **remote box** (optional accessory).
Through the operation of coarse adjustment-fine adjustment, the output can be quickly adjusted to align with the scale of the tested table, which is very convenient to complete the calibration of the analog table. This function is particularly useful when it is necessary to consider the friction or hysteresis effect during movement.

☆ Multiple output\adjustment methods

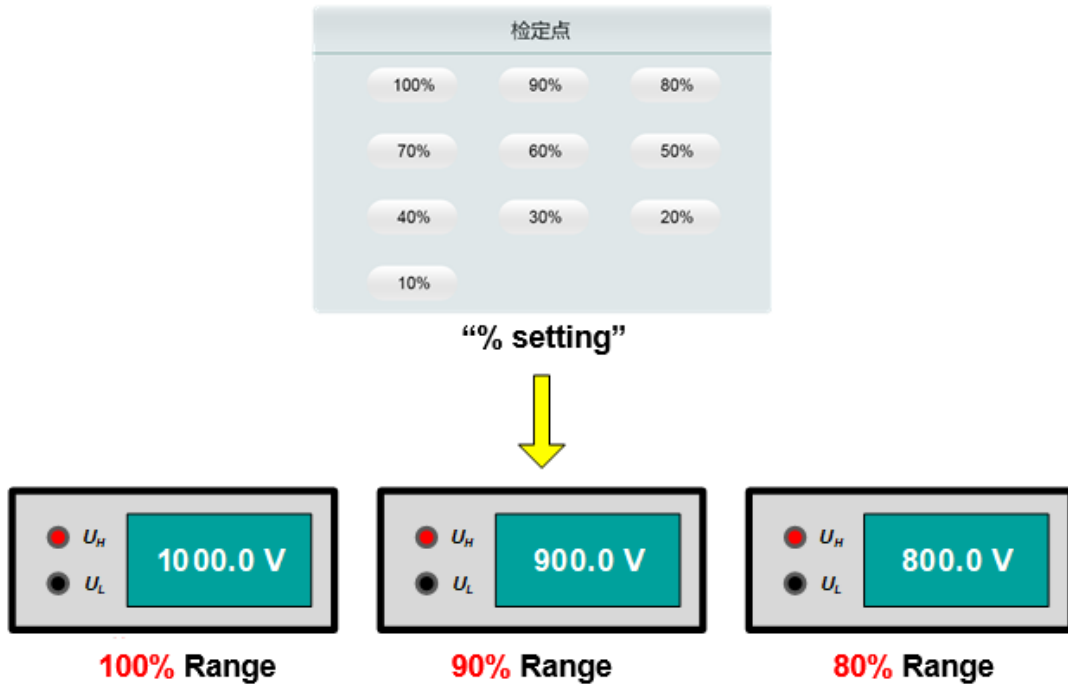

- When calibrating electrical measuring instruments, it is usually necessary to select calibration points according to the proportion of each range of the instrument being tested.
- Users can easily select the calibration points of the instrument being tested through the percentage "**calibration point**" function on the touch screen of this instrument.

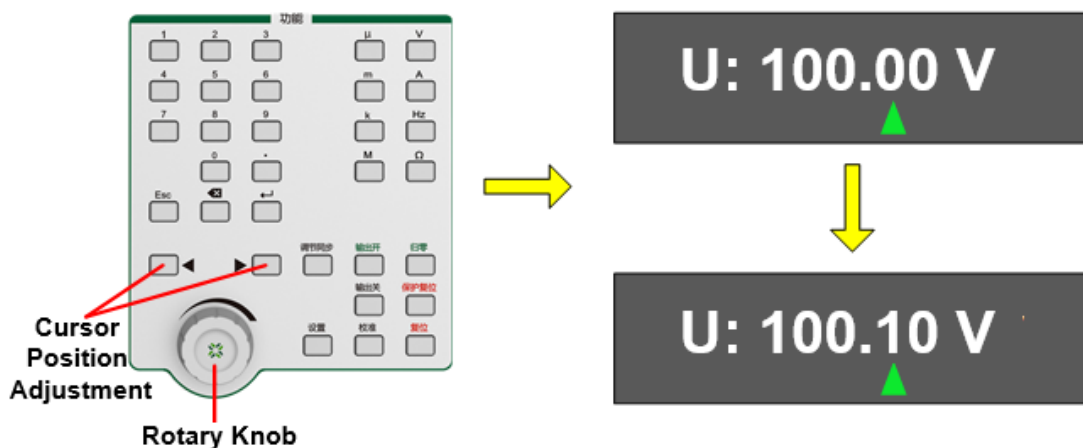

- The instrument is equipped with a "**Rotary Knob**" on the front panel. Click the left and right arrow keys to adjust the cursor position, and then rotate clockwise or counterclockwise to increase or decrease the output value.

6. Specifications

6.1 DC Voltage/Current Output

Range	Resolution	Stability (%/min)	Uncertainty(k=2) (ppm*RD+ppm*RG) ^[1]	Max Burden (mA)	Ripple Factor(%)
200 mV	1 μV	0.01	300 + 200	300	<0.5
2 V	10 μV	0.01	300 + 200	500	<0.5
10 V	100 μV	0.01	300 + 200	500	<0.5
30 V	100 μV	0.01	300 + 200	800	<0.5
100 V	1 mV	0.01	300 + 200	300	<0.5
300 V	1 mV	0.01	300 + 200	100	<0.5
600 V	1 mV	0.01	300 + 200	50	<0.5
1000 V	10 mV	0.01	300 + 200	30	<0.5

Ranges	Resolution	Stability (%/min)	Uncertainty (k=2) (ppm*RD+ppm*RG)	Compliance Voltage (V)	Ripple Factor(%)
20 μA	100pA	0.01	300 + 200	10	<0.5
200 μA	1 nA	0.01	300 + 200	9	<0.5
2 mA	10 nA	0.01	300 + 200	9	<0.5
20 mA	100 nA	0.01	300 + 200	9	<0.5
200 mA	1 μA	0.01	300 + 200	9	<0.5
2 A	10 μA	0.01	300 + 200	3.5	<0.5
10 A	100 μA	0.01	300 + 200	2.5	<0.5
20 A (30 A) ^[2]	100 μA	0.01	300 + 200	2.5	<0.5

Note[1]: RD is the reading value, RG is the range value;

Note[2]: The 30 A range is optional.

- Voltage output range: 20 mV ~ 1100 V
- Current output range: 2 μA ~ 22 A or 33 A
- Protections: voltage source short-circuit protection, current source open-circuit protection, overload protection

6.2 AC Voltage/Current Output

Range	Resolution	Stability (%/min)	Uncertainty (k=2) (ppm*RD+ppm*RG)	Max Burden (mA)	Harmonic (%)
200 mV	1 μ V	50 μ V	300 + 60 μ V	500	<1.0
2 V	10 μ V	0.01	300 + 200	500	<0.5
10 V	100 μ V	0.01	300 + 200	800	< 0.5
30 V	100 μ V	0.01	300 + 200	800	< 0.5
100 V	1 mV	0.01	300 + 200	300	< 0.5
300 V	1 mV	0.01	300 + 200	100	< 0.5
600 V	1 mV	0.01	300 + 200	50	< 0.5
1000 V	10 mV	0.01	300 + 200	30	< 0.5

Range	Resolution	Stability (%/min)	Uncertainty (k=2) (ppm*RD+ppm*RG)	Compliance Voltage (V)	Harmonic (%)
2 mA	10 nA	0.6 μ A	300 +0.6 μ A	50	< 0.5
20 mA	100 nA	0.01	300 + 200	50	< 0.5
200 mA	1 μ A	0.01	300 + 200	50	< 0.5
1 A	10 μ A	0.01	300 + 200	15	< 0.5
2 A	10 μ A	0.01	300 + 200	10	< 0.5
5 A	10 μ A	0.01	300 + 200	5	< 0.5
20 A(30 A) ^[1]	100 μ A	0.01	300 + 200	2.5	< 0.5

Note [1]: 30 A range is optional.

- Voltage output range: 20 mV ~ 1100 V
- Current output range: 200 μ A ~ 22 A or 33 A
- Voltage and current output frequency: 45 Hz ~ 1100 Hz
- Protections: voltage source short-circuit protection, current source open-circuit protection, overload protection

6.3 Simulated DC Resistance

Range	Resolution	Uncertainty (k=2) (ppm*RD+ppm*RG)	Allowable Current
100 Ω	1 mΩ	300 + 200	1mA ~ 80 mA
300 Ω	1 mΩ	300 + 200	1mA ~ 80 mA
1 kΩ	10 mΩ	300 + 200	100μA ~ 8 mA
3kΩ	10 mΩ	300 + 200	100μA ~ 8 mA
10 kΩ	100 mΩ	300 + 200	10μA ~ 0.8 mA
30 kΩ	100 mΩ	300 + 200	10μA ~ 0.8 mA
100 kΩ	1 Ω	300 + 200	10μA ~ 0.8 mA
300 kΩ	1 Ω	300 + 200	1μA ~ 80 μA
1 MΩ	10 Ω	300 + 200	1μA ~ 80 μA
10 MΩ	100 Ω	600 + 400	100nA ~ 8 μA
100 MΩ	1000 Ω	3000 + 2000	10nA ~ 0.8 μA
200 MΩ	1000 Ω	3500 + 2500	10nA ~ 0.8 μA

- Output range: 10 Ω ~ 220 MΩ, continuously adjustable.
- Resistor reverse connection protection

6.4 Sinusoidal Wave Frequency Output

Output Range ^[1]	Resolution	Uncertainty (k=2)
45.0000 Hz ≤ F ≤ 99.9999 Hz	0.0001 Hz	0.01%
100.000 Hz ≤ F ≤ 999.999 Hz	0.001 Hz	0.01%
1000.00 Hz ≤ F ≤ 1100.00 Hz	0.01 Hz	0.01%

Note [1]: The output mode is AC voltage or AC current.

6.5 Pulse Frequency Output

Range ^[1]	Resolution	Uncertainty (k=2)	Shake
1.000 00 Hz ≤ F ≤ 9.999 99 Hz	10 μHz	20 ppm*RD + 20 μHz	<20 ns
10.000 0 Hz ≤ F ≤ 99.999 9 Hz	0.1 mHz		
100.000 Hz ≤ F ≤ 999.999 Hz	1 mHz		
1.000 00 kHz ≤ F ≤ 9.999 99 kHz	10 mHz		
10.000 0 kHz ≤ F ≤ 99.999 9 kHz	0.1 Hz		
100.000 kHz ≤ F ≤ 999.999 kHz	1 Hz		
1.000 00 MHz ≤ F ≤ 2.000 00 MHz	10 Hz		
Note [1]: The output type is TTL level.			

6.6 DC Small-signal Measurement (optional)

Type	Range	Measurement range	Uncertainty (k=2)
DCV	1 V	±(0 ~ 1.2) V	0.006%*RD + 0.004%*RG
	10 V	±(0 ~ 12) V	0.006%*RD + 0.004%*RG
DCI	2 mA	±(0 ~ 2.4) mA	0.006%*RD + 0.004%*RG
	20 mA	±(0 ~ 24) mA	0.006%*RD + 0.004%*RG
Note: This function is used to measure the secondary output signal of the transmitter.			

7. General Specifications

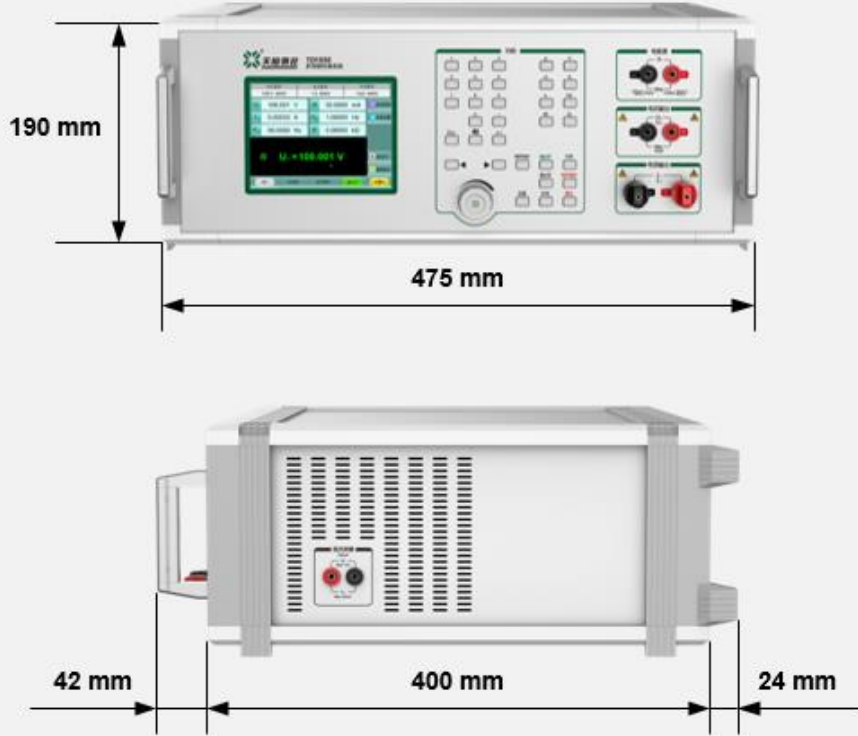
Power supply	AC (220±22) V, (50±2) Hz
Maximum power consumption	600 VA
Warm up time	30 minutes.
Temperature performance	Operating temperature: 0°C ~ 40°C Calibration temperature: 18°C ~ 28°C Storage temperature: -20°C ~ 70°C
Humidity performance	Operating humidity: <80% @ 30°C, <70% @ 40°C Storage humidity: (20%~80%) R·H, No condensation
Altitude	<3000 m
Communication interface	RS 232
Dimensions	475 mm(W) × 400 mm (D) × 190 mm (H), excluding handles and feet.
	
Weight	About 18 kg

8. Ordering Information







TD1850 –



Max Current Range	
Code	Note
20A	20 A
30A	30 A



Transducer Calibration	
Code	Note
Empty	/
T	✓

e.g. : **TD1850-20A-T** notes for the instrument has a max current range of 20A and the function of transducer calibration.

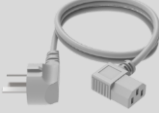
9. Accessories List





S/N	Pic	Name	Specification	Qty	Remark
1		Voltage Test	1.5m / 2.1mm ² / Φ4-Φ4	Red 2	Standard
		Leads	safety banana plug	Black 2	accessory
2		20A Current	1.5m / 6mm ² / Φ4-Φ4	Red 1	Standard
		Test Lead	safety banana plug	Black 1	accessory
3		Current	0.18m / 1.6mm ² / Φ4-Φ4	Red 1	Standard
		Shorting Wire	safety banana plug	Black 1	accessory
4		Alligator Clips	Full sheath / Φ4 banana jack	Red 2	Standard
				Black 2	accessory
5		Pin Adapter	Φ 2*18mm / Φ4 banana jack	Red 2	Standard
				Black 2	accessory
6		U-Shaped Blade Terminal	Φ 8 thin blade terminal / Φ4 banana jack	Red 3	Standard
				Black 3	accessory



7		Frequency Test Leads	BNC Male to Alligator Clip	1	Standard accessory
8		Power Cord	AC 220V, 10A	1	Standard accessory
9		Packing Box	Paper Bag	1	Standard accessory

S/N	Pic	Name	Specification	Qty	Remark
1		30A Current Test Lead	1.5m / 8mm ² / Φ4-Φ4 safety banana plug	Red 1 Black 1	30A current range option
2		Transmitter Auxiliary Power Cable	220V plug to Φ4 safety banana plug	1	Transmitter detection Function options

Note: If the user specifies the function selection in the order contract, the corresponding accessories will be shipped by default.

For example: TD1850-20A-T has a transmitter detection function, so the transmitter auxiliary power cord is included in the delivery list.

S/N	Pic	Name	Specification	Qty	Remark
1		Remote controller	Four-terminal knob adjustment	1	Remote control box options
2		Remote control cable	1.5m / RS232 cable / male-male	1	
3		Current coil	20 A / 50 T	1 个	Clamp meter calibrations options
4		Current test leads	1.5m / 16mm ² / Φ12-Φ12 blade terminal	Red 1 Black 1	

5		Calibration software	Card USB	1set	Software options
6		Communication line	1.8m / USB to RS232 (DB9 female)	1	
7		Storage Box	Aluminum Alloy	1	Packaging options

Note: The above accessories need to be purchased separately and must be specified in the order contract.